

Small, Diffuse Reflective Type with Long Sensing Distance

■ Features

- Realization of long sensing distance (2m) by special optical design
- Protection structure IP64 (IEC standard)
- Built-in stability indicator
- Includes sensitivity adjustment function
- 2 color LED display



⚠ Please read "Safety Considerations" in the instruction manual before using. **CE**

■ Specifications

Model	NPN open collector	BA2M-DDT	BA2M-DDTD
	PNP open collector	BA2M-DDT-P	BA2M-DDTD-P
Sensing type	Diffuse reflective		
Sensing distance	2m (non-glossy white paper 200×200mm)		
Sensing target	Translucent, opaque materials		
Hysteresis	Max. 20% at sensing distance		
Response time	Approx. 1ms		
Power supply	12-24VDC± ±10% (ripple P-P: max. 10%)		
Current consumption	Max. 15mA (max. 30mA when the output is ON)		
Light source	Infrared LED (850nm)		
Sensitivity adjustment	Sensitivity adjuster		
Operation mode	Light ON		Dark ON
Control output	NPN or PNP open collector output ●Load voltage: max. 26.4VDC± ●Load current: max. 100mA ●Residual voltage - NPN: max. 1VDC±, PNP: min. 2.5VDC		
Protection circuit	Reverse polarity protection circuit, output short overcurrent protection circuit		
Indicator	●Operation indicator: red LED ●Stability indicator: orange LED (light on), green LED (dark on)		
Insulation resistance	Over 20MΩ (at 500VDC megger)		
Noise immunity	±240V the square wave noise (pulse width: 1μs) by the noise simulator		
Dielectric strength	1000VAC 50/60Hz for 1 minute		
Vibration	1.5mm amplitude at frequency of 10 to 55Hz (for 1 min) in each X, Y, Z direction for 2 hours		
Shock	100m/s ² (approx. 10G) in each X, Y, Z direction for 3 times		
Environment	Ambient illumination	Sunlight: max. 11,000lx, incandescent lamp: max. 3,000lx (receiving illumination)	
	Ambient temperature	-25 to 55°C, storage: -25 to 70°C	
	Ambient humidity	35 to 85%RH, storage: 35 to 85%RH	
Protection structure	IP64 (IEC standard)		
Material	Case: acrylonitrile butadiene styrene, sensing part: polycarbonate, indicator: polycarbonate, adjuster: IXEF		
Cable	Ø3mm, 3-wire, 2m (AWG24, core diameter: 0.08mm, number of cores: 40, insulator out diameter: Ø1mm)		
Accessory	Adjuster driver		
Approval	CE		
Unit weight	Approx. 50g		

※The temperature or humidity mentioned in Environment indicates a non freezing or condensation environment.

SENSORS

CONTROLLERS

MOTION DEVICES

SOFTWARE

(A) Photoelectric Sensors

(B) Fiber Optic Sensors

(C) LIDAR

(D) Door/Area Sensors

(E) Vision Sensors

(F) Proximity Sensors

(G) Pressure Sensors

(H) Rotary Encoders

(I) Connectors/ Connector Cables/ Sensor Distribution Boxes/ Sockets

BA Series

Feature Data

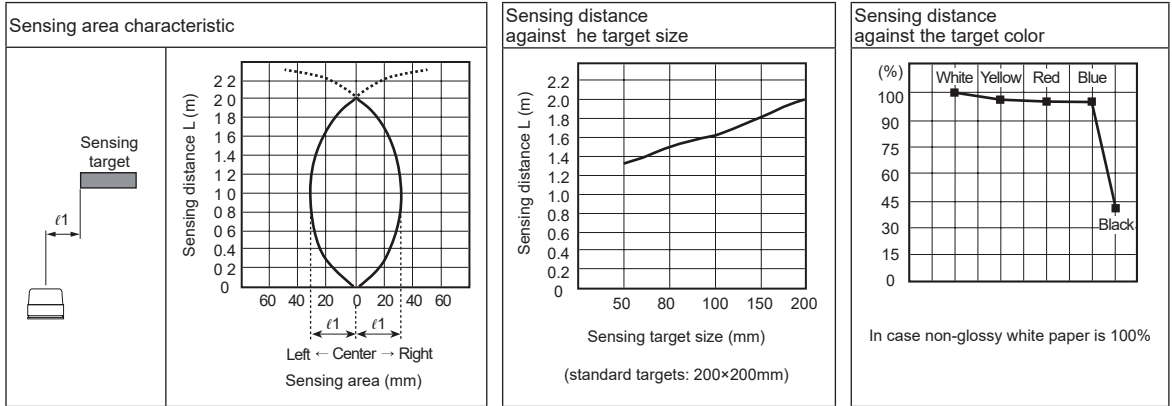

Control Output Diagram

• NPN open collector output

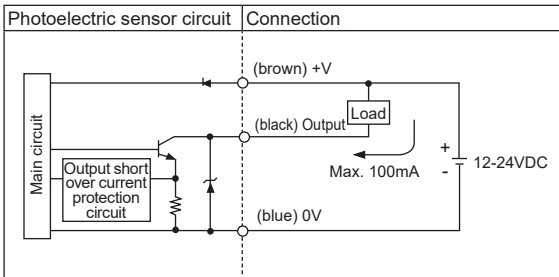

• PNP open collector output

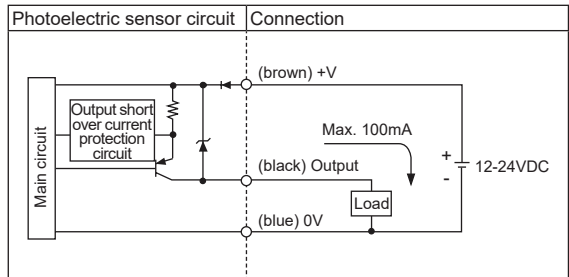

※If short-circuit the control output terminal or supply current over the rated specification, normal control signal is not output due to the output short over current protection circuit.

Connections

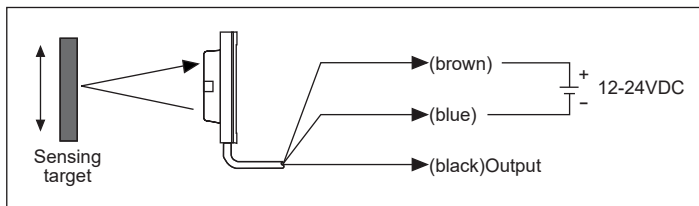

Dimensions

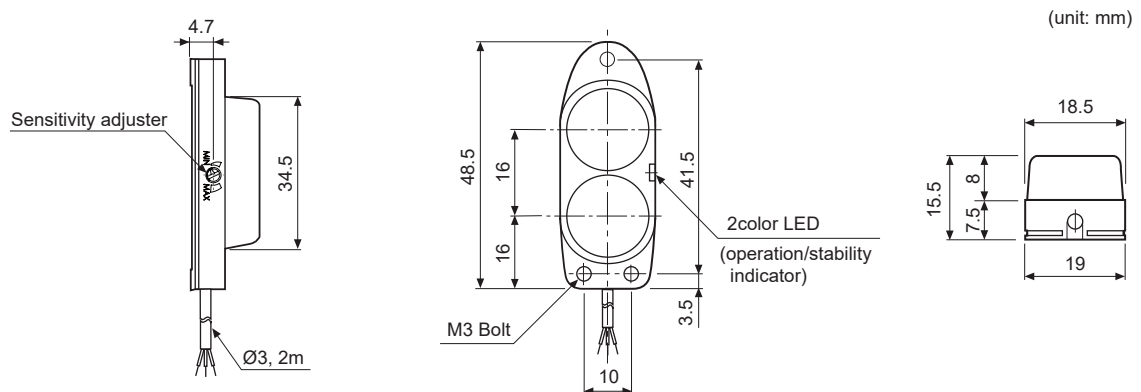

Diffuse Reflective Type with Long Sensing Distance

■ Operation Mode

If the control output terminal is short-circuit or over current than the rated current flows the unit, the sensor does not operate normally by protection circuit.

● Light ON

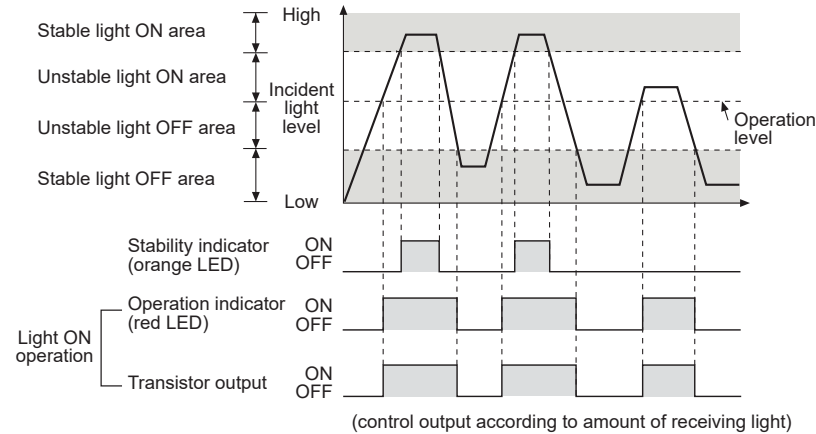

● Dark ON

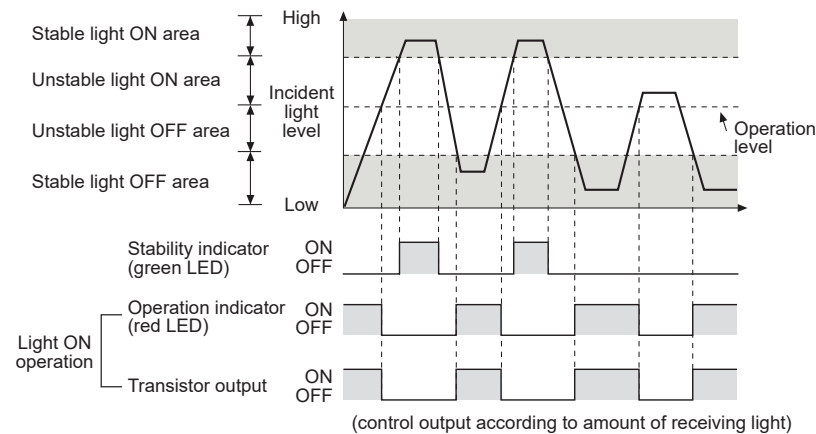

■ Mounting and Sensitivity Adjustment

Install the sensor to the desired place and check the connections.

Supply the power to the sensor and adjust the optical axis and the sensitivity as follow ;

When using photoelectric sensors closely over two units, it may result in malfunction due to mutual interference.

When installing the product, tighten the screw with a tightening torque of 0.5N·m.

● Optical axis adjustment

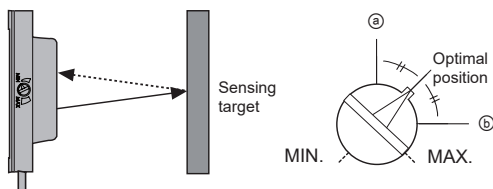

Mount this unit at the center where the stability indicator turns ON with moving the unit toward right or left, up or down.

● Adjustment

1. When sensing the object, set the sensitivity adjuster in stable Light ON area (orange: Light ON, green: Dark ON) as shown '■ Operation mode'.
 2. The sensitivity should be adjusted depending on a sensing target or mounting place.
 3. Set the target at a position to be detected by the beam, then turn the sensitivity adjuster until position ㉑ where the operation indicator turns ON from min. position of the sensitivity adjuster
 4. Take the target out of the sensing area, then turn the sensitivity adjuster until position ㉒ where the operation indicator turns ON. If the indicator dose not turn ON, max. position is ㉒.
 5. Set the sensitivity adjuster at the center of two switching position ㉑, ㉒.
- ※ The sensing distance indicated on specification chart is for 200×200mm of non-glossy white paper. Be sure that it can be different by size, surface and gloss of target.

SENSORS

CONTROLLERS

MOTION DEVICES

SOFTWARE

(A) Photoelectric Sensors

(B) Fiber Optic Sensors

(C) LIDAR

(D) Door/Area Sensors

(E) Vision Sensors

(F) Proximity Sensors

(G) Pressure Sensors

(H) Rotary Encoders

(I) Connectors/
Connector Cables/
Sensor Distribution
Boxes/ Sockets